



PELLET STOVE

CUTE/THEMA AIR

active+GSM⁺
READY!
EASY

Instructions in English

MCZ

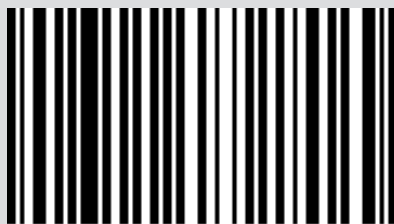

8901301000

TABLE OF CONTENTS

TABLE OF CONTENTS	II
INTRODUCTION	1
1-WARNINGS AND WARRANTY CONDITIONS	2
2-FUEL	6
3-INSTALLATION	7
4-FLUE	8
5-DRAWINGS AND TECHNICAL FEATURES.....	15
6-INSTALLATION AND ASSEMBLY	18
7-REMOTE CONTROL MAX	24
8-EMERGENCY PANEL.....	30
9-OPERATION	31
10-SAFETY DEVICES	33
11-ALARMS	34
12-CLEANING	37
13-FAULTS/CAUSES/SOLUTIONS	43
14-CIRCUIT BOARD	46

INTRODUCTION

Dear Customer,

our products are designed and manufactured in compliance with European reference Standards for construction products (EN13240 wood-burning stoves, EN14785 pellet-burning appliances, EN13229 fireplaces/wood-burning inserts, EN 12815 wood-burning cookers), with high quality materials and extensive experience in the transformation processes. The products also meet the essential requirements of Directive 2006/95/EC (Low Voltage) and Directive 2004/108/EC (Electromagnetic Compatibility).

To get the best performance, we suggest you read the instructions in this manual carefully.

This installation and use manual forms an integral part of the product: ensure that the manual is always supplied with the appliance, even if it changes owner. If the manual is lost, you can request another copy from the local technical service or download it directly from the company website.

All local regulations, including those regarding national and European regulations, must be observed when the appliance is installed.

In Italy, for the installation of systems with biomass below 35KW, refer to ministerial decree D.M. 37/08, and the qualified installation technician with the appropriate requisites must issue a certificate of compliance for the system installed. (By system one means Stove+Chimney+Air inlet).

REVISIONS TO THE PUBLICATION

The content of this manual is strictly technical and the property of MCZ Group Spa.





No part of this manual may be translated into other languages and/or adapted and/or reproduced, even in part, in other mechanical or electronic forms, photocopies, recordings or other, without the prior written authorisation from MCZ Group Spa.

The company reserves the right to make changes to the product at any time without prior notice. The proprietary company reserves its rights according to the law.

CARE OF THE MANUAL AND HOW TO CONSULT IT

- Take care of this manual and keep it in an easily accessible place.
- Should the manual be misplaced or ruined, request a copy from your retailer or directly from the authorised Technical Assistance Department. It can be downloaded from the company website.
- The “**text in bold**” must be read with particular care.
- The “*text in italics*” draws attention to other sections in this manual or clarifications.
- “NOTE” provides the reader with additional information.

SYMBOLS USED IN THE MANUAL

	ATTENTION: read the relative message carefully as failure to observe the information provided could result in serious damage to the product and put the persons who use it at risk.
	INFORMATION: failure to comply with these provisions will compromise the use of the product.
	OPERATING SEQUENCES: sequence of buttons to be pressed to access the menus or change settings.
	MANUAL carefully read this manual or the relative instructions.

1-WARNINGS AND WARRANTY CONDITIONS



SAFETY PRECAUTIONS

- **Installation, electrical connection, function test and maintenance must only be carried out by authorised and qualified personnel.**
- **Install the product in accordance with all local and national legislation and regulations in force in the region or state.**
- Only use the fuel recommended by the manufacturer. The product must not be used as an incinerator. It is strictly forbidden to use liquid fuel.
- Do not put any fuel other than wood pellets in the hopper.
- The instructions provided in this manual must always be complied with to ensure the product and any electronic appliances connected to it are used correctly and accidents are prevented.
- The user, or whoever is operating the product, must read and fully understand the contents of this installation guide before performing any operation. Errors or incorrect settings can cause hazardous conditions and/or poor operation.
- Do not climb on or lean on the product.
- Do not put linen on the product to dry. Any drying racks or the like must be kept at a safe distance from the product. **Fire hazard.**
- *All liability for improper use of the product is entirely borne by the user and relieves the Manufacturer from any civil and criminal liability.*
- Any type of tampering or unauthorised replacement with non-original spare parts could be hazardous for the operator's safety and relieves the company from any civil and criminal liability.
- Many of the surfaces of the product get very hot (door, handle, glass, smoke outlet pipes, etc.). **Avoid coming into contact with these parts, without adequate protective clothing or suitable implements, such as gloves with thermal protection or "cold handle" operating systems.**
- **It is forbidden to operate the product with the door open or the glass broken.**
- The product must be powered by an electrical system that is equipped with an effective earthing device.
- Switch the product off in the event of a fault or malfunction.
- Accumulated unburned pellets in the burner after each "failed start-up" must be removed before lighting again. Check that the burner is clean and positioned properly before lighting again.
- Do not wash the product with water. Water could get inside the unit and damage the electrical insulation and cause electric shocks.
- Do not stand for a long time in front of the product in operation. Do not overheat the room you are in and where the product is installed. This could cause injuries and health problems.
- Install the product in a location that does not feature a fire hazard and is equipped with power and air supplies and smoke extractors.
- In the event of fire in the chimney, turn off the device, disconnect it from the mains electricity and do not open the hatch. Then contact the competent authorities.
- The product and the cladding must be stored in a dry place and must not be exposed to weathering.
- It is recommended not to remove the feet that support the product in order to guarantee adequate insulation, especially if the flooring is made of flammable materials.
- In the event of a malfunction of the ignition system, do not force it to light by using flammable materials.
- Special maintenance must only be performed by authorised and qualified personnel.
- Assess the static conditions of the surface on which the weight of the product will rest and provide suitable insulation if it is made of flammable material (e.g. wood, fitted carpet or plastic).

1-WARNINGS AND WARRANTY CONDITIONS

INFORMATION:

Please contact the retailer or qualified personnel authorised by the company to resolve a problem.

- You must only use the fuel specified by the manufacturer.
- When the product is switched on for the first time it is normal for it to emit smoke due to the paint overheating for the first time. Therefore make sure the room in which it is installed is well ventilated.
- Check and clean the smoke extraction pipes regularly (connection to the chimney).
- The product is not a cooking appliance.
- Always keep the cover of the fuel hopper closed.
- Store this installation and use manual with care as it must accompany the product for the duration of its useful life. If the product is sold or transferred to another user, ensure the manual is also handed over.

INTENDED USE

The product only works with wood pellets and must be installed indoors.

WARRANTY CONDITIONS

The company guarantees the product, **with the exception of elements subject to normal wear** listed below, for a period of **2 (two) years** from the date of purchase attested by:

- a document to serve as proof of purchase (invoice and/or receipt) that shows the name of the vendor and the date on which the purchase was made;
- forwarding of the completed certificate of guarantee within 8 days of purchase.

Furthermore, the product must be installed and started by specialised personnel who must, where provided, issue a declaration of conformity of the plant and of the proper functioning of the product, for the warranty to be valid and effective.

We recommend testing the product before completion with the relative finishes (claddings, painting of walls, etc.).

Installations that do not meet the current standards, improper use and lack of maintenance as expected by the manufacturer, void the product warranty.

The guarantee is valid on the condition that the instructions and warnings contained in the use and maintenance manual are observed, and therefore the product is used correctly.

The replacement of the entire appliance or the repair of one of its components does not extend the warranty period, and the original expiry date remains unchanged.

The warranty covers the replacement or free repair **of parts recognised as faulty at source due to manufacturing defects.**

To benefit from the warranty, in the event of a fault, the customer must have the warranty certificate and show it with the proof of purchase document to the Technical Assistance Office.

1-WARNINGS AND WARRANTY CONDITIONS

EXCLUSIONS

The guarantee does not cover malfunctions and/or damage to the appliance that arise due to the following causes:

- Damage caused during transportation and/or handling
- all parts that develop faults due to negligence or improper use, incorrect maintenance, installation that does not comply with the manufacturer's instructions (always refer to the installation and use manual provided with the appliance)
- incorrect sizing with regard to the use or faults in the installation or failure to adopt the necessary devices to guarantee proper execution
- improper overheating of the equipment, use of fuels not conforming to the types and quantities indicated in the instructions provided
- further damage caused by incorrect user interventions in an attempt to fix the initial fault
- worsening of the damage due to the continued use of the equipment by the user, once the defect has been noticed
- in presence of a boiler, any corrosion, incrustations or breakages caused by water flow, condensation, hardness or acidity of the water, improperly performed descaling treatments, lack of water, mud or limescale deposits
- inefficiency of chimneys, flues or parts of the plant affecting the equipment
- damage caused by tampering with the appliance, atmospheric agents, natural disasters, vandalism, electric shocks, fires, faults in the electric and/or hydraulic system.

The following are also not covered by the warranty:

- parts subject to normal wear such as gaskets, glass, claddings and cast iron grids, painted, chrome-plated or gilded parts, handles and electric cables, bulbs, indicator lights, knobs, all parts which can be removed from the hearth.
- Variations in colour of the painted or ceramic/serpentine parts and craquelure ceramics as they are natural characteristics of the material and product use.
- masonry work
- plant parts (if present) not supplied by the manufacturer

Any technical interventions on the product to eliminate the above-said defects and consequent damages must be agreed upon with the Technical Assistance Centre, who reserves the right to accept the relative appointment or not. However, said interventions will not be carried out under warranty but as technical assistance to be granted at part of any eventual and specific agreed conditions and in accordance with the fee in force for the work to be carried out.

The user will also be charged for any costs incurred to remedy the incorrect technical interventions, tampering or damage to the appliance, not attributable to original faults.

With the exception of the legal or regulatory limits, the warranty does not cover the reduction of atmospheric and acoustic pollution.

The company declines all liability for any damage which may be caused, directly or indirectly, to persons, animals or objects as a consequence of non compliance with any provision specified in the manual, especially warnings regarding installation, use and maintenance of the appliance.

1-WARNINGS AND WARRANTY CONDITIONS

SPARE PARTS

In the event of a malfunction, consult the retailer who will forward the call to the Technical Assistance Service.

Only use original spare parts. The retailer or service centre can provide all necessary information regarding spare parts. We do not recommend waiting for the parts to get worn out before having them replaced. It is important to perform regular maintenance.



The company declines all liability if the product and any other accessory is used improperly or modified without authorisation.

All parts must be replaced with original spare parts.

PRECAUTIONS FOR CORRECT DISPOSAL OF THE PRODUCT IN ACCORDANCE WITH THE EUROPEAN DIRECTIVE 2002/96/EC AND ITS SUBSEQUENT AMENDMENT 2003/108 EC.



At the end of its working life, the product must not be disposed of as urban waste.

It must be taken to a special differentiated waste collection centre set up by the local authorities or to a retailer that provides this service. Disposing of the product separately prevents possible negative consequences for the environment and health deriving from inappropriate disposal and allows its materials to be recovered in order to obtain significant savings in energy and resources.

As a reminder of the need to dispose of appliances separately, the product is marked with a crossed-out wheeled dustbin.

2-FUEL

The instructions in this chapter refer explicitly to the Italian installation regulation UNI 10683. In any case, always observe the regulations in force in the country of installation.

PELLETS

Wood pellets are manufactured by hot-extruding compressed sawdust which is produced during the working of natural dried wood. The compactness of the material is guaranteed by the lignin contained in the wood itself and allows pellets to be produced without glue or binders.

The market offers different types of pellets with characteristics that vary according to the wood mixtures used. The diameter varies between 6 and 8 mm, with a standard length ranging from 5 to 30 mm. A good quality pellet has a density of between 600 and 750 or more kg/metres cubed and a water content that accounts for 5 to 8% of its weight.

Pellets have technical advantages besides being an ecological fuel, as the wood residue is used completely, thereby achieving cleaner combustion than that of fossil fuels.

While good-quality wood has a calorific value of 4.4 kW/kg (15% moisture, after about 18 months of seasoning), whereas that of pellets is around 4.9 kW/kg. To ensure good combustion, the pellets must be stored in a dry place and protected from dirt. Pellets are usually supplied in 15 kg bags, therefore, storing them is very convenient.



15 Kg BAG OF FUEL

Good quality pellets guarantee good combustion, thereby decreasing harmful emissions into the atmosphere.



The poorer the quality of the fuel, the more often the internal parts of the brazier and combustion chamber must be cleaned.

The main quality certifications for pellets currently available on the European market guarantee that the fuel complies with class A1/A2 according to EN14961-2. These certifications include, for example, **ENplus**, **DINplus**, **Ö-Norm M7135**, and in particular, guarantee the following characteristics:

- calorific value: 4.6 ÷ 5.3 kWh/kg.
- Water content: max 10% of the weight.
- Percentage of ash: max 1.5% of the weight.
- Diameter: 5 ÷ 6 mm.
- Length: max 40 mm.
- Content: 100% untreated wood without the addition of binding substances (max 5% bark).
- Packaging: in sacks made from ecologically compatible or biologically decomposing material.



The company strongly recommends using certified fuel for its products (ENplus, DINplus, Ö-Norm M7135). Poor quality pellets or others that do not comply with the characteristics specified previously may compromise the operation of your product and can therefore make the guarantee and product liability invalid.

3-INSTALLATION

FOREWORD

The installation position must be chosen according to the room, to the smoke extraction system, to the chimney flue. Check with local authorities whether there are any restrictive regulations in force regarding the combustion air inlet, the smoke outlet system, the flue or the chimney cap. The manufacturer declines all responsibility in the event of installations that do not comply with the laws in force, incorrect room air exchange, electrical connection non-compliant with the standards and inappropriate use of the appliance. The installation must be carried out by a qualified technician, who must issue a declaration of conformity of the system to the purchaser and will assume full responsibility for final installation and consequent good operation of the product.

In particular one must ensure that:

- there is a suitable combustion air inlet and smoke outlet in compliance with the type of product installed
- other stoves or devices installed do not cause depression in the room where the product is installed (for sealed appliances only, a maximum of 15 Pa of depression in the room is allowed)
- when the product is switched on there is no reflux of smoke in the room
- fumes extraction takes place in total safety (sizing, smoke seal, distances from flammable materials..).

We especially recommend to check the data tags of the flue for the safety distances that must be observed in presence of combustible materials and the type of insulating material to be used. These indications must be followed strictly to prevent serious harm to people and the integrity of the home. The installation of the appliance must ensure easy access to clean the appliance itself, the smoke outlet pipes and the flue. **It is forbidden to install the stove in rooms with a fire hazard. Installation in studio flats, bedrooms and bathrooms is only allowed with sealed or closed appliances equipped with suitable combustion air ducting directly outside. Always maintain adequate distance and protection in order to prevent the product from coming into contact with water.**

In the event there are several appliances installed, the external air inlet must be sized accordingly.

MINIMUM DISTANCES

It is recommended to install the stove detached from any walls and/or furniture, with a minimum clearance to allow effective aeration of the appliance and a good distribution of heat in the room. Observe the distances from flammable or heat-sensitive objects (sofas, furniture, wood panelling, etc..) as specified. The front distance from flammable materials must be at least 80 cm.

If particularly delicate objects are present, such as furniture, curtains or sofas, increase the stove clearance accordingly.



If the floor is made of wood, it is recommended to fit a floor protection sheet in compliance with the Standards in force in the country of installation.

CUTE/THEMA	Non-flammable walls	Flammable walls
	A = 5 cm B = 5 cm	A = 5 cm B = 5 cm

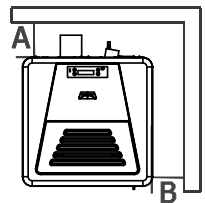

If the floor is made of combustible material, it is recommended to use protection made of non-combustible material (steel, glass...) that also protects the front from falling combusted material during cleaning operations.

The appliance must be installed on a floor with adequate load capacity.

If the existing construction does not meet this requirement, one must take appropriate measures (for example a load distribution plate).

4-FLUE

FOREWORD

The Chimney Flue chapter has been drawn up with reference to the provisions of European Standards (EN13384 - EN1443 - EN1856 - EN1457).

The chapter provides instructions for installing a chimney flue efficiently and properly, but under no circumstances is it a substitute of the Standards in force, which the qualified technician must be in possession of. Check with local authorities whether there are any restrictive regulations in force regarding the combustion air inlet, the smoke outlet system, the flue or the chimney cap.

The company declines all liability relating to the poor functioning of the stove if this is due to the use of an insufficiently sized flue in violation of the Standards in force.

CHIMNEY FLUE

The flue or chimney is of great importance for the proper operation of a solid fuel-burning heating appliance with forced draught, as modern heating appliances have high efficiency with cooler flue gasses and consequently less draught, it is therefore essential that the flue is built up to standard and always kept in perfect order. A flue that serves a pellet/wood fuelled appliance must be at least category T400 (or greater if the appliance requires so) and resistant to soot fires. Smoke must be extracted through a single flue made of insulated steel (A) or an existing flue that complies with the intended use (B).

A simple air shaft made of cement must be suitably lined. In both solutions there must be an inspection cap (AT) and/or inspection hatch (AP) - FIG.1.

It is forbidden to connect more than one wood/pellet-burning appliance or of any other kind (vent hoods...) to the same flue.

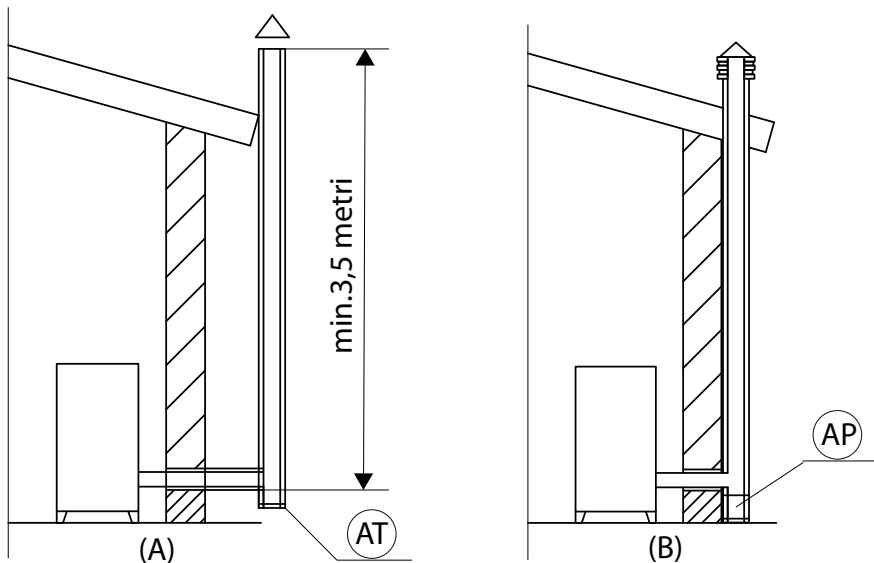

FIGURE 1 - SMOKE FLUE

4-FLUE

TECHNICAL CHARACTERISTICS

Have the efficiency of the flue checked by an authorised technician.

The flue must be sealed against flue gasses, in a vertical direction without narrowing, be made with materials impermeable to smoke, condensation, thermally insulated and suitable to resist normal mechanical stress over time (we recommend fireplaces made of A/316 or refractory material with insulated round section double chamber). Be suitably insulated externally to avoid condensation and reduce smoke cooling. It should be separated from combustible or flammable materials with an air gap or insulating materials: check the distance specified by the manufacturer of the fireplace according to EN1443. The chimney opening must be in the same room as the appliance, or at most in the adjoining room, and have a soot and condensation collection chamber beneath the opening, and be accessible via a sealed metal hatch.

FLAT ROOF

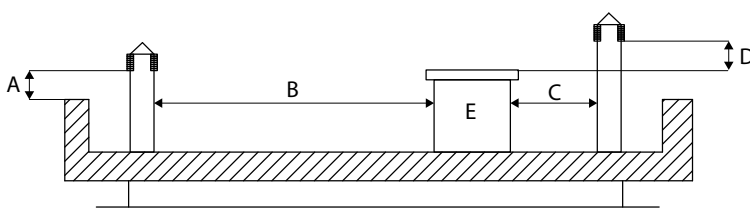

A = 0.50 metres
B = DISTANCE > 2 metres
C = DISTANCE < 2 metres
D = 0.50 metres
E = TECHNICAL VOLUME

FIGURE 2

ROOF AT 15°

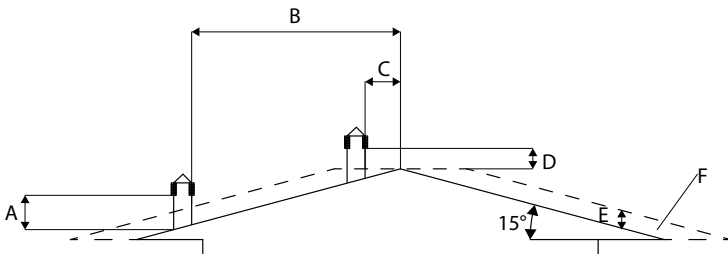

A = MIN. 1.00 metres
B = DISTANCE > 1.85 metres
C = DISTANCE < 1.85 metres
D = 0.50 metres above highest point
E = 0.50 metres
F = REFLUX AREA

FIGURE 3

ROOF AT 30°

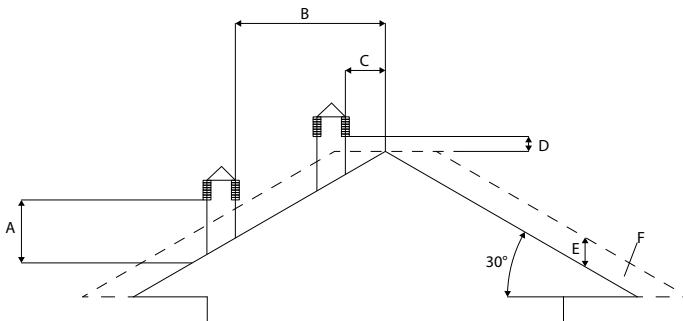

A = MIN. 1.30 metres
B = DISTANCE > 1.50 metres
C = DISTANCE < 1.50 metres
D = 0.50 metres ABOVE HIGHEST POINT
E = 0.80 metres
F = REFLUX AREA

FIGURE 4

4-FLUE

ROOF AT 60°

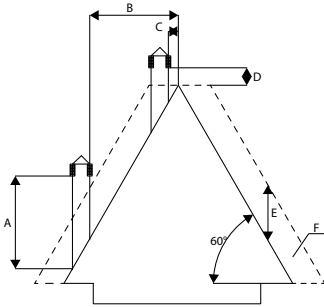

FIGURE 5

- A = MIN. 2.60 metres
- B = DISTANCE > 1.20 metres
- C = DISTANCE < 1.20 metres
- D = 0.50 metres ABOVE HIGHEST POINT
- E = 2.10 metres
- F = REFLUX AREA

ROOF AT 45°

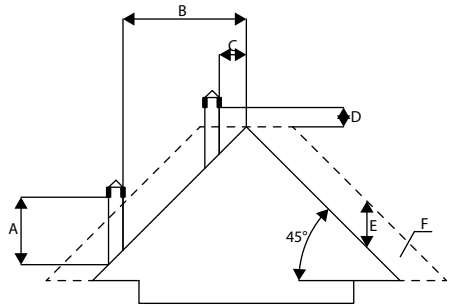

FIGURE 6

- A = MIN. 2.00 metres
- B = DISTANCE > 1.30 metres
- C = DISTANCE < 1.30 metres
- D = 0.50 metres ABOVE HIGHEST POINT
- E = 1.50 metres
- F = REFLUX AREA

SIZING

The depression (draught) of a flue depends on its height. Check the depression with the values indicated in the technical characteristics. The minimum height of the chimney is 3.5 metres.

The interior cross-section of the flue can be round (best), square or rectangular (the ratio between the internal sides must be ≤ 1.5) with the sides joined with a minimum radius of 20 mm. The dimension of the cross-section must be **minimum $\varnothing 100\text{mm}$** .

The cross-sections/lengths of the chimneys shown in the technical data tables are indications for correct installation. Any alternative configurations must be correctly sized in accordance with the general method of calculation of UNI EN13384-1 or other proven efficiency methods.

Below is a list of some flues available on the market:

AISI 316 steel chimney with double chamber insulated with ceramic fibre or equivalent resistant up to 400°C.

Refractory chimney with double insulated chamber and external lightweight concrete cladding with cellular material such as clay.

Traditional square-section clay chimney with insulating empty inserts.

Avoid products with an internal rectangular section where the larger side is 1.5 times the smaller side (e.g. 20x40 or 15x30).

EXCELLENT

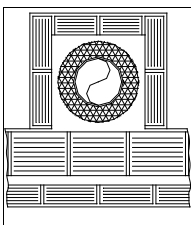

GOOD

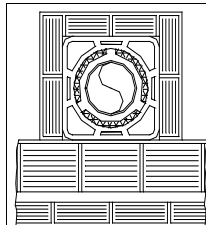

POOR

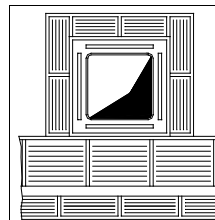

VERY POOR

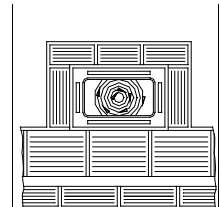

4-FLUE

MAINTENANCE

The flue must be kept clean, since the deposit of soot or unburned oils reduces the cross-section reducing the draft and thus compromising the efficient operation of the stove and, if large build-ups accumulate, can catch fire. The flue and chimney must be cleaned and checked by a qualified chimney sweep at least once a year. Once maintenance has been performed, request a written declaration that the system is safe.

Failure to clean the system jeopardises safety.

CHIMNEY CAP

The chimney cap is a crucial element for the heating appliance to work properly: we recommend a wind proof chimney cap (A), see Figure 7.

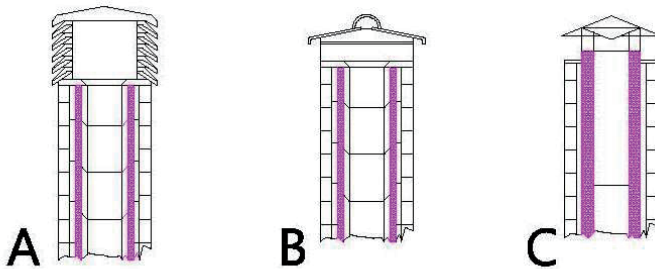

The area of the openings for smoke extraction must be at least double the cross-section of the smoke duct/flue system, and arranged so that smoke extraction is ensured even in strong wind. The chimney must prevent rain, snow or animals from entering the chimney. The height of outflow into the atmosphere must be beyond the reflux area due to the shape of the roof or any obstacles near the outlet (see Figures 2-3-4-5-6).

FIGURE 7

CHIMNEY COMPONENTS

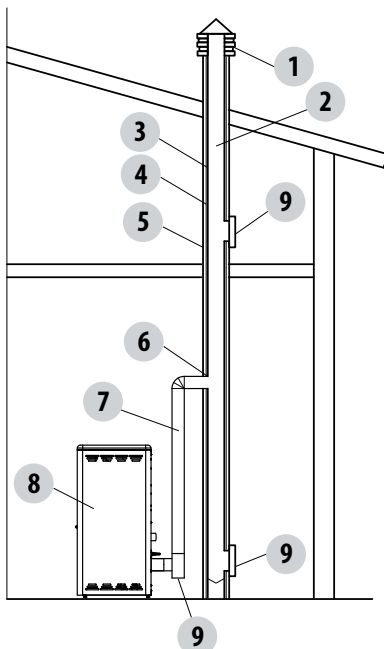

- KEY:
- (1) CHIMNEY CAP
 - (2) REFLUX CHANNEL
 - (3) SMOKE DUCT
 - (4) THERMAL INSULATION
 - (5) OUTSIDE WALL
 - (6) CHIMNEY CONNECTION
 - (7) SMOKE CHANNEL
 - (8) HEAT GENERATOR
 - (9) INSPECTION ACCESS PANEL

FIGURE 8

4-FLUE

EXTERNAL AIR INLET

It is mandatory to provide an adequate external air intake that supplies the combustion air required for the product to work properly. The flow of air between the outside and the installation room may be direct, through an inlet in an external wall of the room; or indirect, via air intake from adjoining rooms and connecting permanently with the installation room (see Figure 9 b). Adjoining areas may not include sleeping areas, garages or general areas that present a fire hazard. During installation one must check the minimum clearances required for air intake from outside. Take into account the presence of doors and windows that could interfere with the proper flow of air to the stove (see diagram below).

The air intake must have a minimum total net area of 80 cm²: the surface must be increased accordingly if within the room there are other active generators (for example: electric fan for stale air extraction, kitchen hood, other stoves, etc...), which could cause cause depression in the room. One must verify that, with all the equipment on, the pressure drop between the room and the outside does not exceed a value of 4 Pa. If necessary increase the intake section of the air inlet, which must be made at floor level and always protected with a bird-proof outer protection grid and in such a way that it cannot be obstructed by any object.

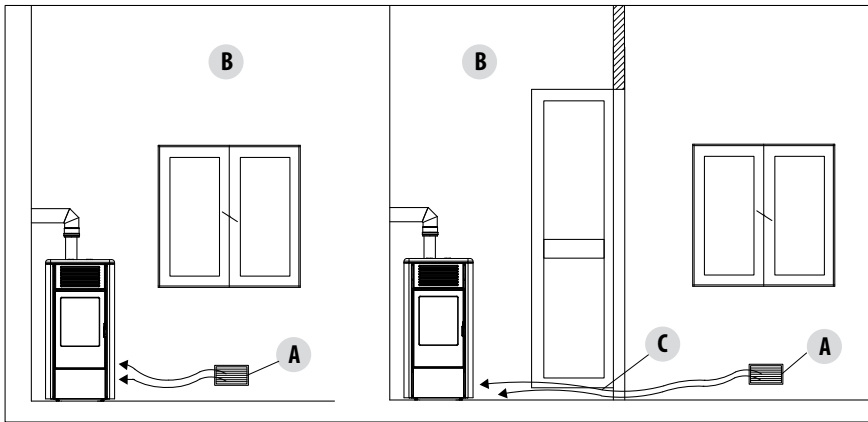
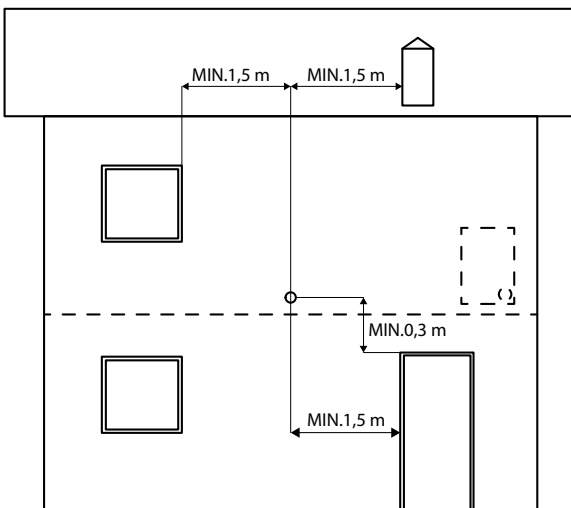

FIGURE 9 A - DIRECTLY FROM OUTSIDE

FIGURE 9 B - INDIRECTLY FROM THE ADJACENT ROOM

A=AIR INLET
B=ROOM TO BE VENTILATED
C=INCREASE OF THE GAP UNDER THE DOOR



It is possible to connect the air required for combustion directly to the outside air inlet, with a pipe of at least Ø50mm, with maximum length of 3 linear metres; each pipe bend shall be considered equivalent to a linear metre. To attach the pipe see the back of the stove.

For stoves installed in studio flats, bedrooms and bathrooms (where allowed), it is mandatory to connect the combustion air outside. In particular for sealed stoves the connection must be sealed in order not to compromise the overall sealed characteristic of the system.

FIGURE 10

4-FLUE

DISTANCE (metres)	The air inlet must be at a distance of:	
1.5 m	UNDER	Windows, doors, smoke outlets, cavities,
1.5 m	HORIZONTALLY	Windows, doors, smoke outlets, cavities,
0.3 m	ABOVE	Windows, doors, smoke outlets, cavities,
1.5 m	AWAY	from smoke outlet

CONNECTION TO THE FLUE

The connection between the flue and the appliance must be via a smoke duct that complies with EN 1856-2. The connecting section must extend no more than 4 m horizontally, with a minimum slope of 3% and with a maximum of 3 90° bends (accessible for inspection - do not count the T fitting at the appliance outlet).

The diameter of the smoke duct must be equal to or greater than that of the appliance outlet (Ø 80 mm).

TYPE OF SYSTEM	SMOKE DUCT
Minimum vertical length	1.5 metres
Maximum length (with 1 accessible 90° bend)	6.5 metres
Maximum length (with 3 accessible 90° bends)	4.5 metres
Maximum number of accessible 90° bends	3
Horizontal sections (minimum slope 3%)	4 metres

Use smoke ducts with a diameter of 80mm or 100mm depending on the type of system, with silicone gaskets or similar gaskets that can withstand the high operating temperatures of the appliance (min. T200 class P1). **The use of flexible metal hoses made of fibre cement or aluminium is forbidden. For direction changes, we always recommend using a T fitting** with an inspection cap allowing easy access to clean the pipes. Always ensure that the inspection cap is put back in place and sealed hermetically with the relevant seal intact after cleaning.

It is forbidden to connect several appliances to the same smoke duct, or the outlet from the overhead hoods. It is forbidden to extract the combustion products directly through the wall, whether into indoor spaces or outdoors.

The smoke duct must be at a minimum distance of 400 mm from flammable or heat-sensitive structures.

4-FLUE

EXAMPLES OF CORRECT INSTALLATION

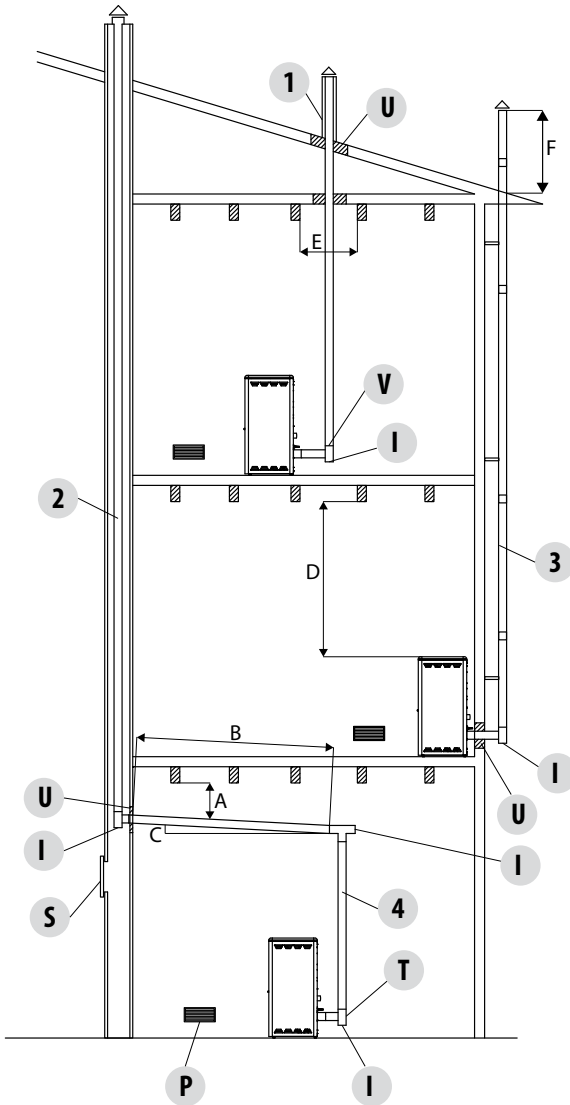

1. Installation of $\varnothing 120\text{mm}$ flue with hole for the passage of the pipe increased by: minimum 100mm around the pipe if next to non flammable parts such as cement, brick, etc.; or minimum 300mm around the pipe (or as required by data tags) if next to flammable parts such as wood etc. In both cases, install suitable insulation between the flue and the ceiling.

Always check and respect the data tags on the flue, in particular the minimum safety distances from combustible materials.

The previous rules also apply for holes made in walls.

2. Old flue, minimum pipe $\varnothing 100\text{mm}$ with the inclusion of an external access door for chimney cleaning.

3. External flue made of insulated stainless steel pipes, i.e. with double walls minimum $\varnothing 100\text{mm}$: all securely mounted on the wall. With wind-proof chimney cap. See fig. 7 type A.

4. Ducting system using T fitting that allow easy access for cleaning without having to remove the pipes

FIGURE 11

U = INSULATING
 V = ANY REDUCTION FROM 100 TO 80 MM
 I = INSPECTION CAP
 S = INSPECTION ACCESS PANEL
 P = AIR INLET
 T = T JOINT WITH INSPECTION CAP

A = MINIMUM 40 MM
 B = MAXIMUM 4 M
 C = MINIMUM 3°
 D = MINIMUM 400 MM
 E = HOLE DIAMETER
 F = SEE FIG. 2-3-4-5-6

5-DRAWINGS AND TECHNICAL FEATURES

DRAWINGS AND CHARACTERISTICS

CUTE AIR STOVE DIMENSIONS

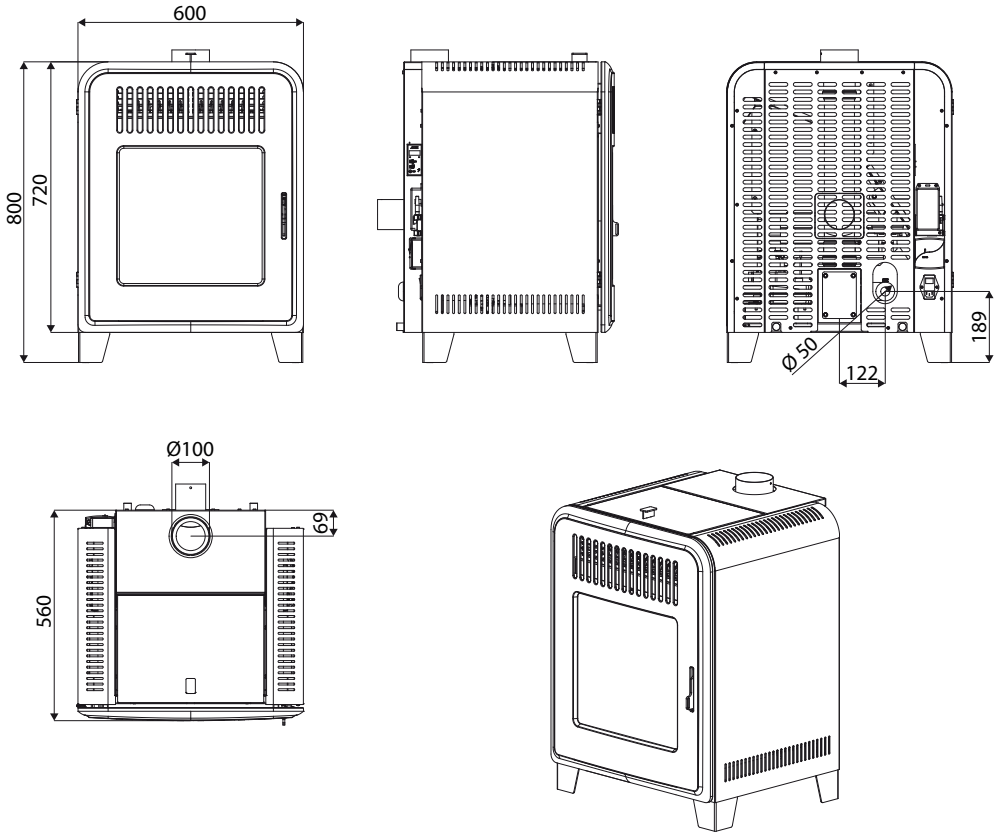

5-DRAWINGS AND TECHNICAL FEATURES

THEMA AIR STOVE DIMENSIONS

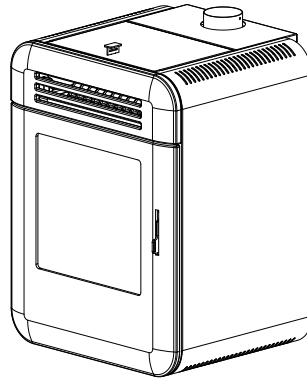
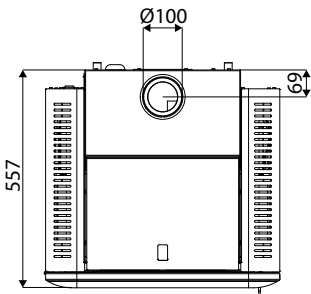
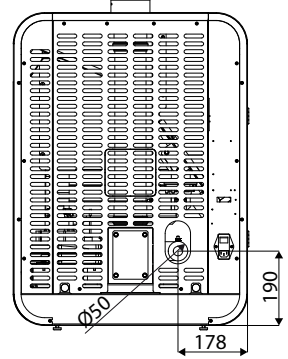
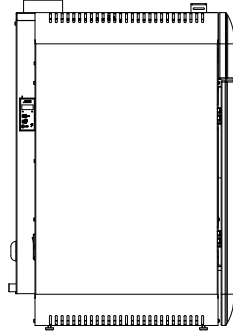
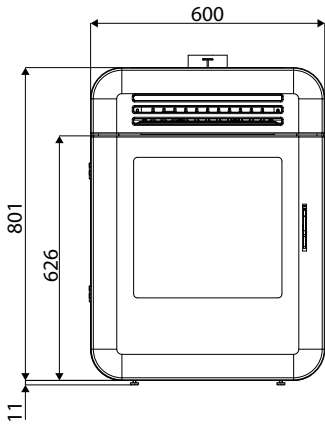

5-DRAWINGS AND TECHNICAL FEATURES

TECHNICAL CHARACTERISTICS	CUTE/THEMA Model AIR
Nominal output power	8 kW (6880 kcal/h)
Minimum output power	2,4 kW (2064 kcal/h)
Efficiency at Max	90,5%
Efficiency at Min	90,0%
Temperature of exhaust smoke at Max	170 °C
Temperature of exhaust smoke at Min	100 °C
Particulate /OGC / Nox (13%O ₂)	<13 mg/Nm ³ - 5 mg/Nm ³ - 107 mg/Nm ³
CO at 13% O ₂ at Min and at Max	0,060 – 0,018%
CO ₂ at Min and at Max	4,5% - 9,0%
Recommended draught at Max power	0,10 mbar - 10 Pa
Recommended draught at Min power	0,05 mbar - 5 Pa
Smoke mass	6,2 g/sec
Hopper capacity	20 litres
Type of pellet fuel	Pellet diameter 6-8 mm and size 5/30 mm
Pellet hourly consumption	Min ~ 0,7 kg/h* - Max ~ 1,8 kg/h*
Autonomy	At min ~ 20 h* - At max ~ 7 h*
Heatable volume m ³	172/40 – 197/35 – 229/30 **
Combustion air inlet	Ø 50 mm
Smoke outlet	Ø 80/100*** mm
Air inlet	80 cm ²
Rated electrical power (EN 60335-1)	55 W (Max 400 W)
Supply voltage and frequency	230 Volt / 50 Hz
Net weight	130 kg
Weight with packaging	140 kg
Distance from combustible material (rear\sides\floor)	50/50/0 mm
Distance from combustible material (ceiling/front)	800/800 mm

* Data that may vary depending on the type of pellets used

** Volume that can be heated, according to the power requirement per m³ (respectively 40-35-30 Kcal/h per m³)

***Using the adapter supplied with the product

Head according to EN 14785 in agreement with the EU Building Products Regulation (EU 305/2011).

6-INSTALLATION AND ASSEMBLY

PREPARATION AND UNPACKING

The packaging consists of a recyclable cardboard box according to RESY standards, recyclable EPS foam inserts, wooden pallets. All packaging materials can be reused for similar use or eventually disposed of as urban solid waste, in compliance with the regulations in force.

After having removed the packaging make sure the product is intact.



Handle the product with suitable means paying attention to the applicable safety regulations in force. Do not turn the packaging over and handle the majolica parts with care.

The stove **CUTE/THEMA** is delivered in a single package. Open the package, remove the two screws "v" which secure the stove brackets to the pallet and then remove the bracket "S" from the stove foot.

Install the stove in the chosen area, making sure it complies with the requirements.

The stove body or unit must always be kept in a vertical position when handled, and handled using carts only. Pay particular attention to the door and its glass, protecting them from mechanical knocks that would compromise their integrity.

The product must always be handled with care. If possible, unwrap the stove near the chosen area of installation.

The packaging materials are neither toxic nor harmful, therefore no particular disposal measures are required.

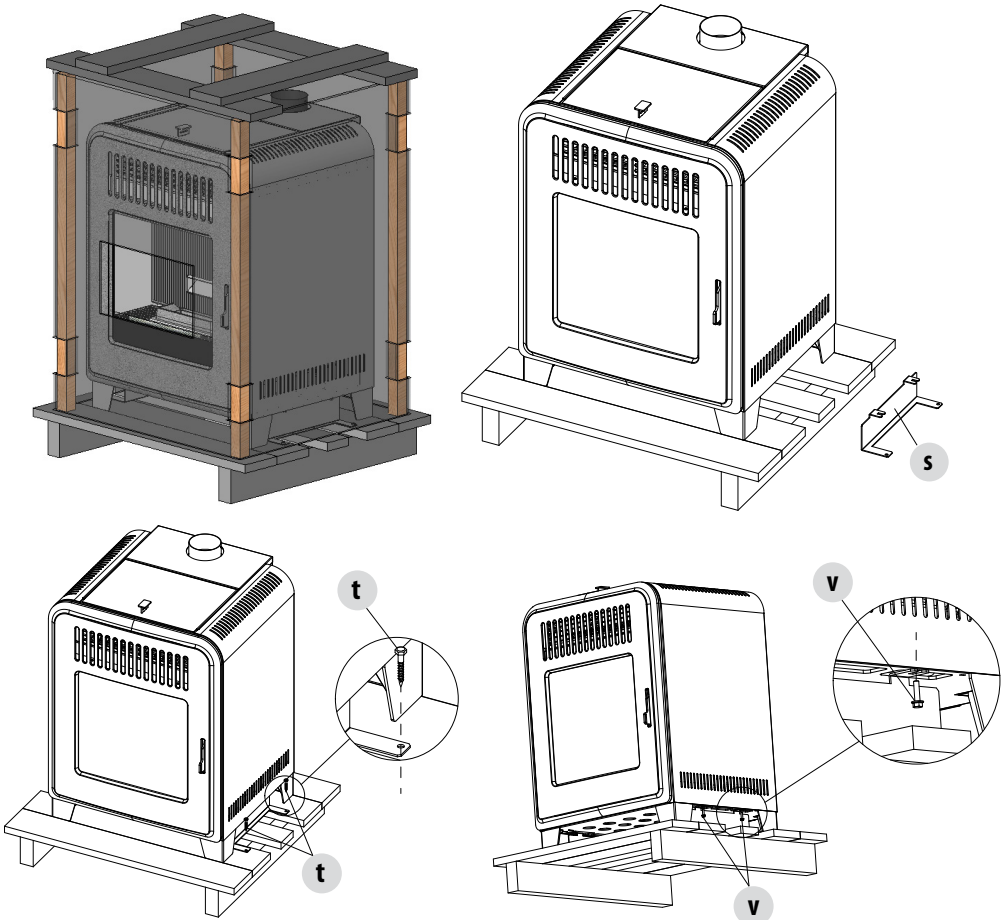

6-INSTALLATION AND ASSEMBLY

Therefore, the end user is responsible for product storage, disposal or possible recycling in compliance with the relative applicable laws in force. Do not store the stove unit or its cladding without their packaging.

Position the stove and connect it to the flue pipe.

If the stove needs to be connected to an outlet pipe which goes through the rear wall (to connect to the flue), take utmost care to make sure that the joint is not forced.



If the stove smoke outlet is forced or used improperly to lift it or position it, the operation of the stove can be damaged irreparably.

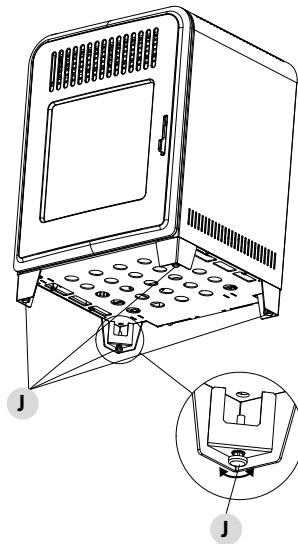

1. TURN THE FEET CLOCKWISE TO LOWER THE STOVE
2. TURN THE FEET COUNTERCLOCKWISE TO LIFT THE STOVE

THEMA STOVE CERAMIC/STEATITE PACKAGING

The front panel of ceramic or soapstone will have a packaged separately and will then be installed on the stove

6-INSTALLATION AND ASSEMBLY

DISASSEMBLING THE SIDE CLADDING

In the event the side has to be removed, proceed as follows:

- Open the door "P"
- Remove the two screws "v" at the front of the stove
- Remove the two screws "t" at the back of the stove
- Pull out the panel "S"

Proceed with the same system for the other panel as well.

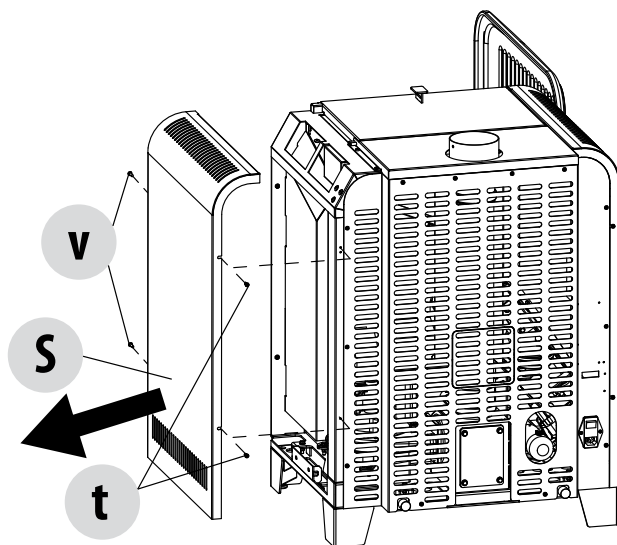
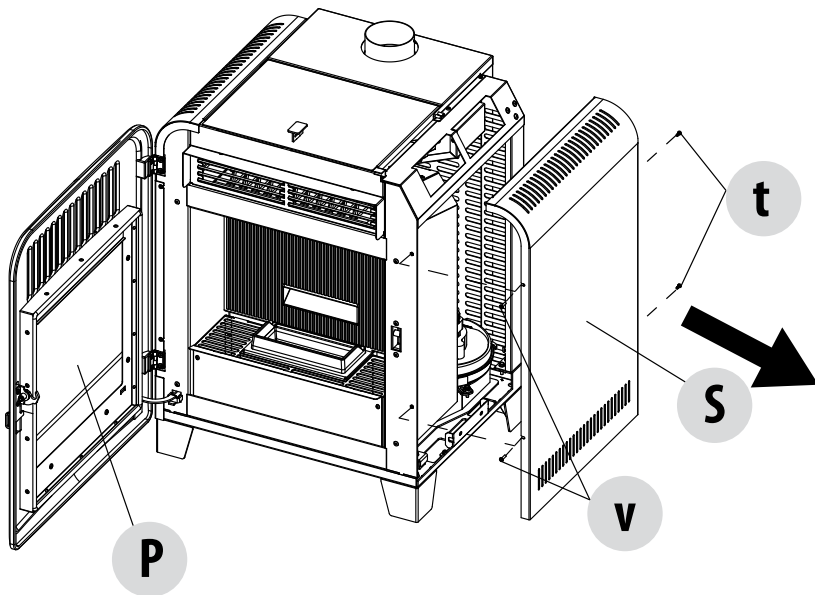

6-INSTALLATION AND ASSEMBLY

ASSEMBLING THE THEMA STOVE CERAMIC/STEATITE

Take the front panel (ceramic or steatite) "G" and fit the slots "P", located at the back of the panel, on the screws "O" on the front of the stove. Then clamp the panel to the stove by tightening the two screws "O" via the holes in the panel "G" itself.

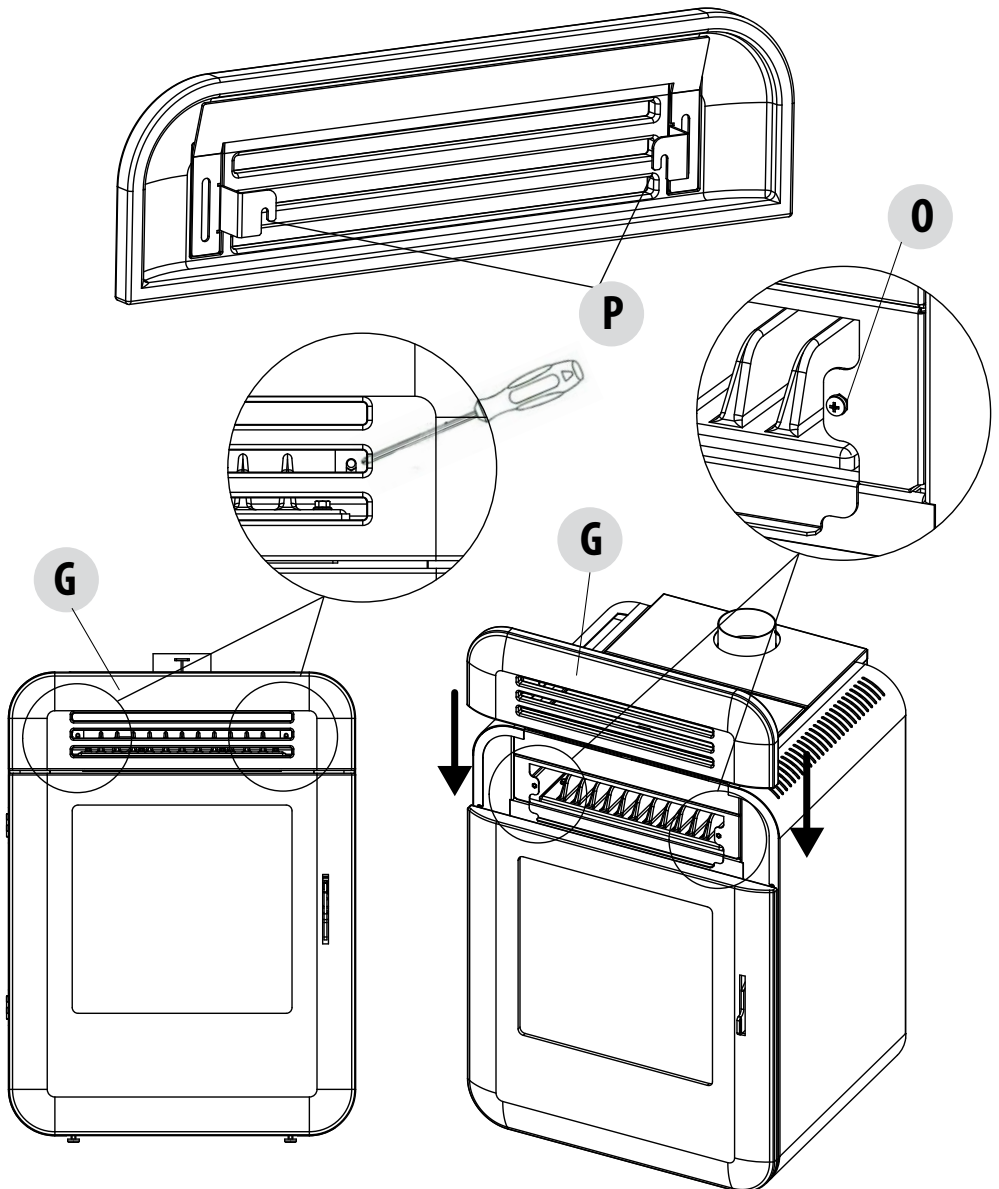

6-INSTALLATION AND ASSEMBLY

LOADING THE PELLETS

Fuel is loaded from the upper part of the stove by lifting the door.

Pour the pellets in slowly so that it is deposited at the bottom of the hopper.



Never remove the protection grid inside the hopper. When loading, do not let the pellet bag come into contact with hot surfaces.



No other type of fuel other than pellets is to be inserted into the hopper, in compliance with above-mentioned specifications.

Store the spare fuel at an adequate safe distance.

Do not pour pellets directly onto the brazier but only into the hopper.

Most of the stove surfaces are very hot (door, handle, glass, smoke outlet pipes, hopper door etc.), therefore it is recommended to avoid coming into contact with these parts without appropriate protective clothing.

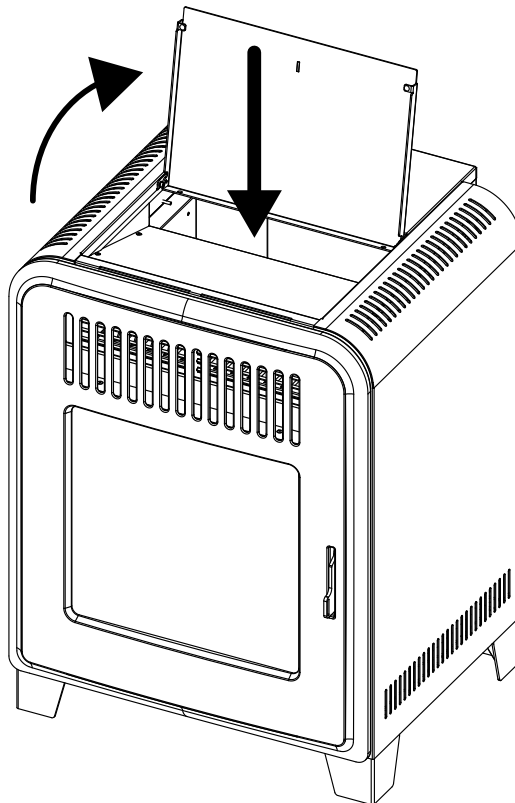

LOADING THE PELLETS

6-INSTALLATION AND ASSEMBLY

PRECAUTIONS BEFORE START-UP

GENERAL PRECAUTIONS

Remove any objects that may burn from the brazier (manual, various adhesive labels or any polystyrene).

Check that the brazier is positioned correctly and rests properly on the base.



The first start-up may not be successful as the feed screw is empty and does not always manage to load the required amount of pellets in time to light the flame.



CANCEL THE FAILED IGNITION ALARM BY PRESSING AND HOLDING THE ON/OFF KEY FOR A FEW SECONDS. REMOVE THE PELLETS LEFT IN THE BRAZIER AND REPEAT THE START-UP. (SEE "SAFETY DEVICES/ALARMS" PARAGRAPH)

If after repeated attempts, the flame fails to ignite, despite a regular flow of pellets in the brazier, which **must rest snugly against the slots and be clean without any ash incrustations**. If no anomaly is found during this inspection, there may be a problem with the product components or installation may not be correct.



REMOVE THE PELLETS FROM THE BRAZIER AND CONTACT AN AUTHORISED TECHNICIAN.



Do not touch the boiler during the first lighting, as it is during this phase that the paint sets. If you touch the paint, you may expose the steel surface.

If necessary, touch up the paint with the spray can of the specific colour. (See "Pellet stove accessories")



It is good practice to ensure effective ventilation in the room during the initial start-up, as the boiler will emit some smoke and smell of paint.

Do not stand close to the stove and as mentioned, air the room. The smoke and smell of paint will disappear after about an hour of operation, however, they are not harmful in any case.

The boiler will be subject to expansion and contraction during the lighting and cooling down stages, and may therefore make slight creaking noises.

This is absolutely normal as the structure is made of laminated steel and must not be considered a defect.

It is extremely important to make sure the boiler does not reach high temperatures straight away, but to increase the temperature gradually using low power at first.

This will prevent damaging the ceramic or serpentine stone tiles, the welds and the steel structure.



DO NOT EXPECT HEATING EFFICIENCY IMMEDIATELY!!!

7-REMOTE CONTROL MAX

GENERAL FEATURES OF THE LCD REMOTE CONTROL

The remote control works at a transmission frequency of 434.5 MHz. Power the product with 3 AAA batteries as follows:
Remove the battery compartment cover by pressing and lifting according to the arrow
Insert the batteries observing the correct polarity (+) and (-)
Close the battery compartment cover.

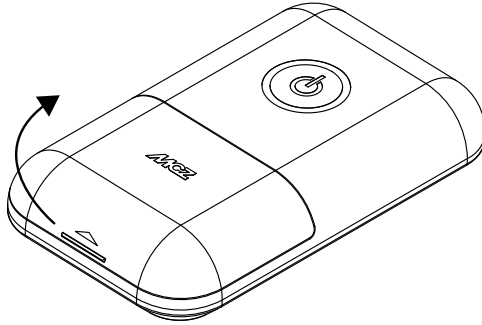

When the remote control is powered it automatically prompts to set the time.

The remote control has a special icon on the display to indicate when the batteries are almost flat. If the flat battery icon appears, the batteries are almost flat and the remote control is about to switch off.



Used batteries contain metals which are harmful to the environment, so they must be disposed of separately in appropriate containers.

GRAPHIC APPEARANCE

In the instructions we will often refer to the indications of the keys shown in the figure. Always keep it at hand for simplicity's sake.

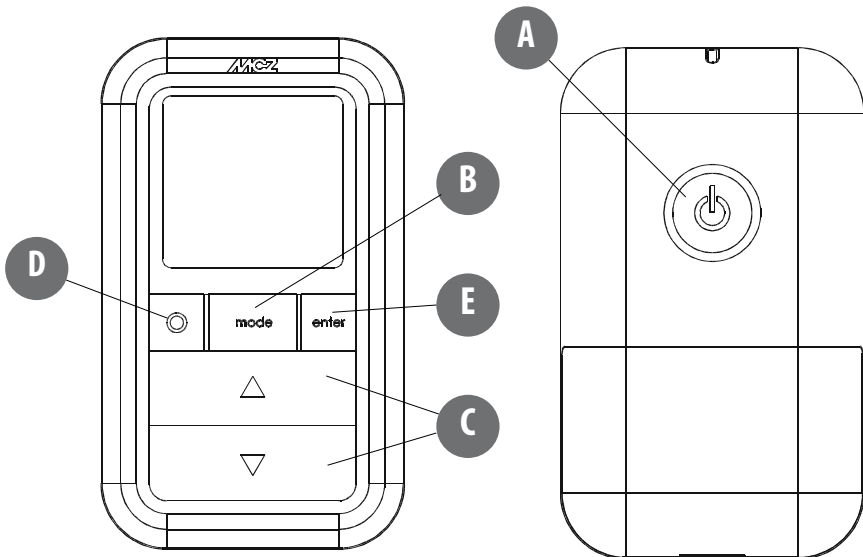

7-REMOTE CONTROL MAX

REMOTE CONTROL OPERATION

General rules

By pressing key **A** for 1" the product is switched on and off. Key **C** is used to make all changes. Key **E** is used to confirm the changes. By pressing key **B** one selects the product operating mode. Via key **D** one browses the FAN and SLEEP setting. Whichever the mode is, press key **A** briefly (or leave the keypad idle for 7") to go back to the initial display.

INITIAL SETTINGS

Setting the time

Both with the remote control on and off, by pressing keys **B+E** at the same time for 3" one accesses the time/day setting mode. The hour digits will start to flash; they can be changed with key **C**. By pressing key **E** the changes are confirmed. At this point the minutes digits will start to flash.

Follow the same modify/confirm procedure, one will then go onto the time display mode (12h or 24h) and finally the day will start to flash. Confirm this data to exit the settings.

NOTE: each time the remote control is powered, the time is reset and the display automatically enters the time setting mode.

°C – °F setting

Only with the stove switched off, by pressing key **B** for 5" one changes the unit of measure of the temperature, from Celsius to Fahrenheit and vice versa.

SETTING THE OPERATING MODE

With the remote control switched on, key **B** allows to set one of the 4 product operating modes. Figure 1-2-3-4 displays the 4 basic displays, respectively:

Manual, Automatic, Timer and Eco mode.

MANUAL Mode (MAN)

In this mode one can set the flame power manually (5 levels - act directly on key C to change) and the ventilation power on 5 levels + auto. **Figure 1**

AUTOMATIC Mode (AUTO)

In this mode one can set the desired room temperature, and the stove will modulate the flame power automatically to reach the temperature. Ventilation can be adjusted on 5 levels + auto. **Figure 2**

FIG.1



FIG.2



7-REMOTE CONTROL MAX

TIMER Mode (TIMER)

Select this operating mode to switch the product on and off automatically, according to 6 customised time slots (P1 – P6). The following can be set for each time slot:

- Switch-on time
- Switch-off time
- Desired room temperature in the time slot
- Days of the week in which the time slot is active

When the stove is switched on (manually via key **A** or automatically via a time slot) the product works in the automatic mode described above. A time slot appears automatically when it is active (P1 in **figure 3**) and the desired temperature is changed according to the value set in the time slot. However, the user can always modify this value as desired and in real time.

Refer to the relevant paragraph to learn how to set the time slots.

FIG.3

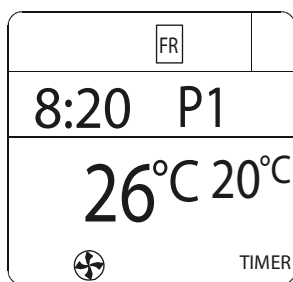

FIG.4



FIG.5



ECO Mode (ECO)

This mode is activated/disabled with the remote control switched on by pressing key **B** for 5".

ECO is an automatic mode with the only difference that if the set temperature is reached and remains so for the following 20 minutes (despite flame modulation), the product switches off and remains on stand-by until the room temperature drops 2 degrees below the desired temperature (and in any case for at least 5 minutes from the last shutdown). The product is then switched on again. **Figure 4** If the room is not sufficiently insulated, flame modulation does not allow the set temperature to stay satisfied for 20 consecutive minutes and the product will not switch off.

NOTE: It is recommended to use the ECO mode only in well-insulated rooms in order to prevent start-up and shutdown from occurring within short periods of time.

The remote control remains on even when the product is off when in ECO mode, in order to indicate that this shutdown is only temporary. Obviously, if the product is switched off via key **A**, ECO mode is exited and the product remains off.

Up to 6 automatic start-up and shutdown time slots (E1 – E6) can also be set in ECO mode, which are independent from those of TIMER mode (P1 – P6). If they have been activated, TIMER-ECO appears on the display (**figure 5**) permanently, even if the remote control is switched off.

Refer to the relevant paragraph to learn how to set the time slots.

NOTE: If the remote control is switched off due to TIMER, ECO cannot be restarted until the user intervenes (key **A) or when the next valid time slot starts. Combined use of TIMER and ECO modes requires a good knowledge of the product operating logic.**

7-REMOTE CONTROL MAX

VARIOUS SETTINGS

Room ventilation

Room ventilation can be adjusted as desired in all 4 operating modes described above. Simply perform this operation: from the basic display, press key **D** to access the VENTILATION adjustment mode (**figure 6**). Then press key **C** to set the desired ventilation by selecting one of the 5 levels available, independent from the flame level. The “auto” option can also be selected, which automatically links the room ventilation speed to the flame level.

In short:

flame set on 1 > ventilation set on 1; flame set on 3 > ventilation set on 3; flame set on 5 > ventilation remains set on 3 (to make operation more silent as it is in automatic mode).

In products with 2 room fans (comfort air models) via key **D** one can scroll and set the speed of the individual fans (identified with 1 or 2 above the level bars).

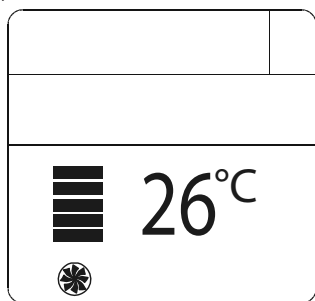

FIG.6

NOTE: In the event a replacement remote control is purchased, if you need to change the default setting, proceed as follows: with the remote control switched on press buttons D + E at the same time for 10 seconds (until the flashing number appears). Press key C to select 1 or 2 according to the product to which the remote control is to be paired, and press E to exit.

Sleep function

The sleep mode allows to quickly set the time at which the product must switch off. This function is only available in MAN and AUTO mode. It is set as follows: from the VENTILATION setting (by pressing key **D** - see previous paragraph), press key **D** again to access the SLEEP mode setting.

Via key **C** one can adjust the shutdown time in 10 minute intervals.

By confirming with **D** or **E** one goes back to the basic display, in which the sleep mode shutdown time is any case visible (**figure 7**).

To disable the SLEEP mode simply access the settings, decrease the time until the dashes appear and confirm.

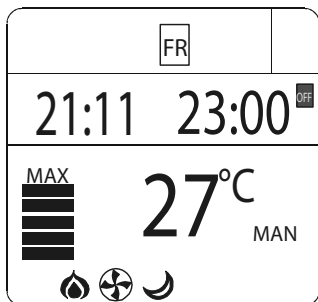

FIG.7

7-REMOTE CONTROL MAX

SILENT FUNCTION (SF)

The **SILENT** function allows the stove to operate at the minimum power throughout the whole night and, therefore, to turn off the room's ventilation. This function is only available in **AUTO** and **MAN** (mode, not in **TIMER** mode). Proceed as follows to set it:

from the **VENTILATION** adjustment (by pressing key **D**), press key **D** again and you will enter the **SLEEP** adjustment area.

From when the dashes "--" are displayed, press lower key **C** and the **SILENT** function is activated (**SF** appears on the display); by confirming with **D** or **E** one goes back to the basic display where **SF** and the moon image are still displayed.

Once the function is activated, the flame power goes onto 1 and the ventilation switches off after about 5 minutes to be able to dispose of the excess heat.

When this function is active, nothing happens when **C** the keys are pressed. To disable the **SILENT** function, access the **SLEEP** setting, press upper key **C** to make the dashes "--" appear and confirm with keys **D** or **E**.

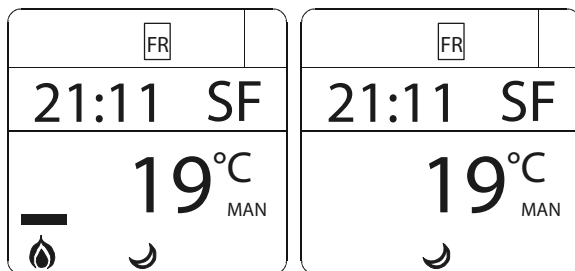

7-REMOTE CONTROL MAX

TIMER settings

TIMER time slot display

In TIMER mode, to display the time slots simply press key **D** for 2". With key **C** one can scroll the 6 time slots freely, quickly checking the saved settings (**figure 8**). By pressing key **D** or **A** one goes back to the basic display.

Modifying the TIMER time slots

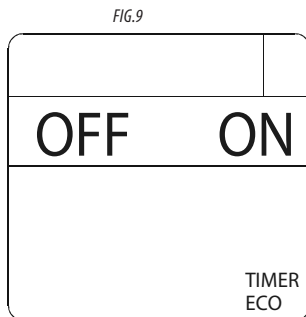
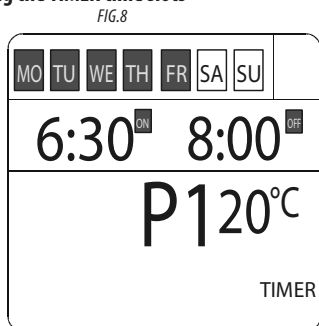

To modify a time slot, display it as described in the previous paragraph and then press key **E**. The first parameter to be set will start to flash, i.e. room temperature. Press key **C** to modify the value and key **E** to confirm and set the next parameter. The parameters of a time slot can be set in the following sequence:

- Room temperature. Can be set between 5° and 35°C. 2 dashes "--" appear if set below 5°C or above 35°C, and if this is confirmed, the programme is disabled (therefore, the product will not be switched on).
- Switch-on time. The value is adjusted in 10 minute intervals (from 00:00 to 23:50)
- Switch-off time. The value is adjusted in 10 minute intervals (from 00:10:00 to 24:00).
- Days of the week in which the programme is active. Monday (MO) will start to flash, followed by the other days of the week. Use key **C** to activate/disable the day. The activated days will be displayed on a dark background. When the Sunday (SU) setting is complete, press key **E** to exit the editing page and return to the time slots display.

By pressing key **D** at any time one exits the time slot editing mode, saving all variations confirmed with key **E** up to that time, and one goes back to the time slot display condition.

While by pressing key **A** (or leaving the keypad idle for 30") one goes directly to the basic display, saving all variations confirmed with key **E** up to that time.

Activating the TIMER-ECO time slots

In ECO mode one can activate up to 6 time slots, customising switch-on and switch-off (E1 – E6): by pressing key **D** for 2" the TIMER activation/disabling function will appear (**figura 9**). If the ON option is confirmed one can display/modify the 6 time slots of the TIMER-ECO with the same procedure described previously for the TIMER. By confirming the OFF option, the TIMER is disabled and the product goes back to operate in ECO mode without active time slots.

REMOTE CONTROL SYNCHRONIZATION

When the product is started up for the first time, it may be necessary to synchronize the new remote control with the stove. To do this, follow these simple instructions:

- connect the socket to the stove and turn on the power switch
- make sure the selector D on the emergency panel is in the REMOTE position
- when the first message appears on the emergency panel's display, use a pointed object to press the chased G button (toothpick, etc.)
- the panel's display will show 3 flashing lines "--". Press the remote control's on/off button to launch the learning process.

The three flashing lines will disappear from the display and the stove will learn the remote control's new communication address. The learning process is also confirmed by 4 audio signals.

8-EMERGENCY PANEL

There is an emergency panel on the side-rear part of the stove, designed to detect any malfunctions and also for product control if the remote control is not working.

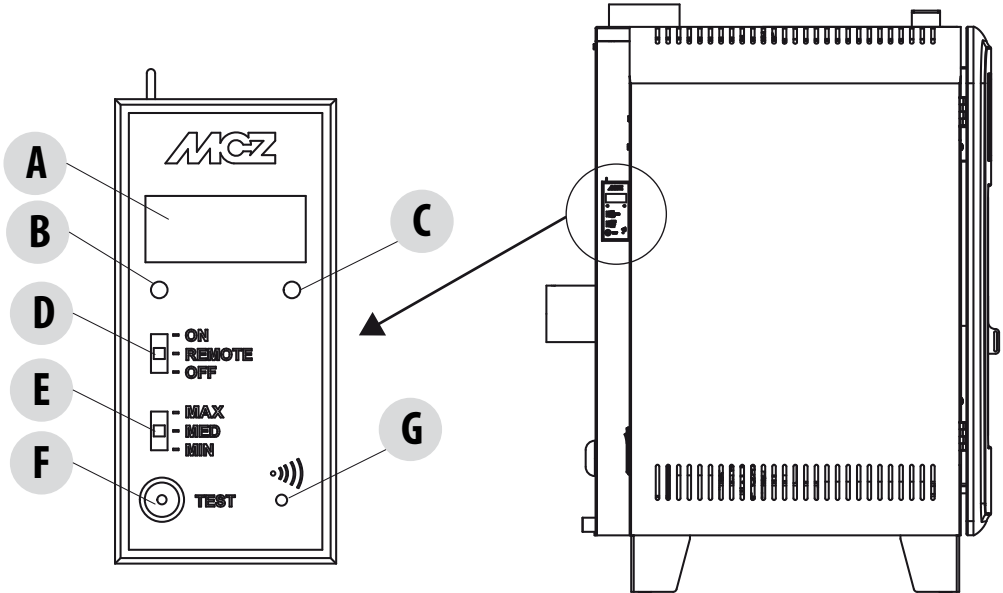

KEY

A - DISPLAY; indicates a series of information on the stove, as well as the identification code of any malfunction.

B - GREEN LED that indicates:

- OFF = Stove off
- FLASHING ON = Stove in ignition stage
- FIXED ON = Stove on

C - RED LED that indicates:

- OFF = Stove on
- ON WITH SLOW FLASHING = Stove in shutdown stage
- ON WITH FAST FLASHING = Stove in alarm conditions (combined with a beep sound for the first 10 minutes)
- FIXED ON = Stove off

D - Three-position selector for the following functions

- OFF = Stove switched off manually without remote control
- REMOTE = Stove controlled **exclusively** from the remote control
- ON = Stove switched on manually without the remote control

E - Three-position selector to select the power

- MIN = Selector to make the stove work at MINIMUM power without the remote control and with selector 4 on ON
- MED = Selector to make the stove work at MEDIUM power without the remote control and with selector 4 on ON
- MAX = Selector to make the stove work at MAXIMUM power without the remote control and with selector 4 on ON

F - Button for diagnostic functions relating to the operating status of the stove

G - Button to put the stove in communication with a new remote control (via the procedure explained below)

SELECTOR "D" MUST BE SET ON "REMOTE" TO MAKE THE STOVE OPERATE WITH THE REMOTE CONTROL.

9-OPERATION

ELECTRICAL CONNECTION

First connect the power cable to the back of the stove and then to a wall socket.

The main switch must only be activated to switch the stove on; otherwise, it is advisable to keep it switched off.



It is recommended to disconnect the power cable when the stove is not used.

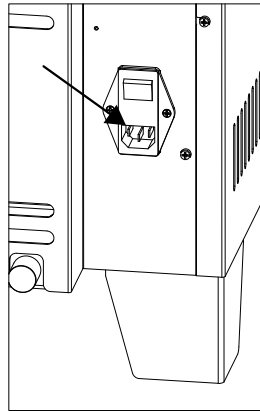

ELECTRICAL STOVE CONNECTION

STOVE POWER SUPPLY

After connecting the power cable to the back of the stove, turn the switch at the back to position (I).

The luminous switch button will light up.

The switch on the back of the stove is used to power the system.

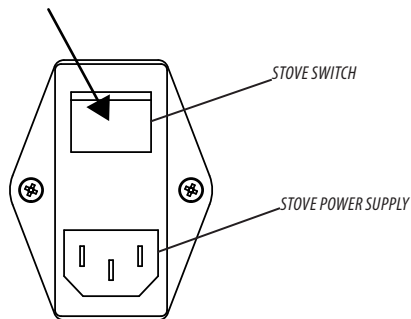

On the rear of the stove there is a fusebox which is located near the power socket. Open the fusebox cover with a screwdriver and replace the fuse if necessary (3.15 A delayed) - seek assistance from an authorised and qualified technician.

9-OPERATION

Switch-on/off from the emergency panel

If the remote control is faulty or the batteries are flat, the product can be operated in safe mode via the rear emergency panel. In this configuration, the stove can only operate in manual mode and with the possibility to choose between 3 power levels.

- **SWITCHING THE STOVE ON WITHOUT THE REMOTE CONTROL**

To switch the stove on move selector "D" to the ON position. The RED LED goes off upon start-up, while the GREEN LED starts to flash until the start-up stage is complete. Once the product is in steady state, the GREEN LED remains on.

- **CHOOSING THE POWER WITHOUT THE REMOTE CONTROL**

One can choose between 3 heating powers:

MIN-MED-MAX (selector "E")

The **MINIMUM** power corresponds to the 1st power;

The **MEDIUM** power corresponds to the 3rd power;

The **MAXIMUM** power corresponds to the 5th power;

- **SWITCHING THE STOVE OFF WITHOUT THE REMOTE CONTROL**

To switch the stove off move selector "D" to the "OFF" position.



Once the remote control is restored, remember to set selector "D" back to the "REMOTE" position, otherwise the product will ignore the remote control commands.

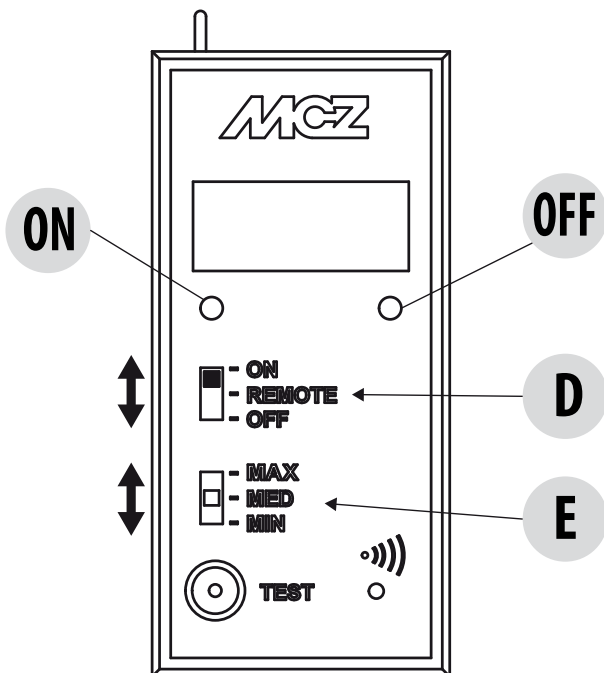

10-SAFETY DEVICES

SAFETY DEVICES

The product is fitted with the following safety devices.

SMOKE TEMPERATURE PROBE

It detects the temperature of the smoke, thereby enabling start-up or stopping the product when the temperature drops below the preset value.

PELLET HOPPER TEMPERATURE PROBE

If the temperature exceeds the preset safety value, it immediately stops the product, which must cool down before the stove is restarted.

ELECTRICAL SAFETY

The product is protected against power surges by a general fuse located in the control panel on the back. Other fuses that protect the circuit boards are located on the latter.

SMOKE FAN BREAKAGE

If the fan stops, the circuit board promptly blocks the supply of pellets and the alarm is displayed.

GEAR MOTOR BREAKAGE

If the gear motor stops, the product switches off and the relative alarm is signalled.

TEMPORARY POWER CUT

If a power cut occurs during operation, the product automatically sets itself in cooling mode when the power is restored and then stays off.

FAILED START-UP

If no flame lights during start-up, the product will go into alarm conditions.



TAMPERING WITH THE SAFETY DEVICES IS PROHIBITED.

It is possible to relight the product and therefore restore the automatic operation of the probe only after having eliminated the cause of the intervention of the safety system. This manual will help you understand which anomaly has occurred, and explain how to intervene according to the alarm message displayed on the appliance.

11-ALARMS

ALARM ALERTS

In the event an operating anomaly occurs the stove starts switching off due to the alarm and informs the user of the type of fault that has taken place via a 3 digit code which stays displayed on the rear emergency panel.

The alarm is indicated permanently by the relative 3 digit code, by a flashing red LED that lights up on the emergency panel and an intermittent sound signal for the first 10 minutes of the alarm. Read the instructions in the following 2 paragraphs to cancel the alarm status and restore the normal operating mode of the stove.

The following table describes the possible alarms indicated by the stove, associated to the respective code that appears on the emergency panel and helpful tips to solve the problem.

MESSAGE ON DISPLAY	TYPE OF PROBLEM	SOLUTION
A01	The fire does not ignite	Check the level of pellets in the tank. Check that the brazier rests correctly in its seat and has no visible deposits of unburned pellets. Check whether the ignition plug heats up.
A02	The flame is goes out unexpectedly	Check the level of pellets in the tank. Check that the brazier rests correctly in its seat and has no visible deposits of unburned pellets.
A03	The temperature of the pellet hopper exceeds the required safety threshold. The structure overheats due to reduced heat dissipation.	The structure is too hot because the product has been used for too long at the maximum power or due to poor ventilation or because the air fans are faulty. When the product is sufficiently cold, press button B on the control panel or OFF on the remote control to cancel alarm A03. Once the alarm is canceled, the product can be switched on normally.
A04	The temperature of the exhaust smoke has exceeded certain preset safety limits.	The stove switches off automatically. Let the stove cool down for a few minutes and then switch it on again. Check the smoke expulsion and the type of pellets used.
A05	Chimney flue clogged - wind - door open.	Check the smoke duct and make sure the door is closed.
	The smoke extractor fails to guarantee sufficient primary air, required for correct combustion.	Draught difficulties or brazier clogged. Check whether the brazier is clogged and clean it, if necessary. Check and if necessary clean the smoke duct and air inlet.
A08	Abnormal operation of smoke fan	Check cleanliness of the fumes fan compartment and check if dirt is blocking it. If this is not enough, the smoke fan is faulty. Contact an authorised service centre to have it replaced.
A09	The smoke probe is faulty and does not detect the exhaust smoke temperature properly.	Contact an authorised service centre to have the component replaced.
A11	Pellet supply fault	Contact an authorised service centre to have the component replaced.

11-ALARMS

A12	The remote control has been out of the reception range of the stove for over three hours (or the batteries are flat). NOTE: only in this case, the stove does not enter the shutdown stage due to an alarm, and continues to work in the mode set by the remote control via the last command.	Move the remote control within the reception range of the stove (or change the remote control batteries in the event they are flat). The alarm alerts will disappear as soon as the appliance receives a new signal from the remote control. A simple way of forcing signal transmission to the stove is by pressing button B (which changes the operating mode from manual to automatic and vice versa).
A13	Overtemperature in the electronic control unit.	The structure is too hot because the product has been used for too long at the maximum power or due to poor ventilation or because the air fans are faulty. When the product is sufficiently cold, press button B on the control panel or OFF on the remote control to cancel alarm A13. Once the alarm is canceled, the product can be switched on normally.
A14	Faulty air flow rate sensor	This alarm does not block the stove, just a warning is displayed. Contact an authorised service centre to have the component replaced.
SER	Routine maintenance alert	When this flashing message appears upon start-up it indicates that the preset operating hours before maintenance is due have elapsed and that an MCZ qualified technician must be contacted for maintenance.

Exiting the alarm conditions

Follow the procedure described below to restore normal stove operation after an alarm has been triggered:

- Put selector D on the rear emergency panel on OFF for a few seconds, until the 3 digit alarm identity code disappears. The red LED stops flashing and the sound signal is silenced by performing the steps below.
- Put selector D back in the REMOTE position, to control the operation of the stove via the remote control.
- Switch off the remote control and switch it on again if one wants to restart the stove.



Only if alarm A12 is triggered (no communication between the remote control and the stove), the stove stay on according to the last mode set and automatically exits the alarm mode when the first signal is received from the remote control.

11-ALARMS

Mechanical stove block

The following conditions may cause the mechanical stove block:

- Structure overheating ("A03")
- Smoke overheating ("A04")
- During stove operation air has entered the combustion chamber or there is an obstruction in the chimney flue ("A05")

The block is signalled on the display and with a sound signal. In this situation the shutdown stage is activated automatically. When this procedure is started, any test operation to restore the system is useless. The display signals the cause of the blockage.

SOLUTIONS:

If "**A03**" appears: the structure is too hot because the product has been used for too long at the maximum power or due to poor ventilation or because the air fans are faulty.

When the product is sufficiently cold, press button B on the control panel or **OFF** on the remote control to cancel alarm **A03**. Once the alarm is canceled, the product can be switched on normally.

If "**A04**" appears: The stove switches off automatically. Let the stove cool down for a few minutes and then switch it on again. Check the smoke expulsion and the type of pellets used.

If "**A05**" appears: the door has been left open for too long or a significant amount of air has entered (e.g. missing smoke fan inspection cap). If these causes are excluded, check and if necessary clean the smoke duct and flue. (it is recommended that this operation is carried out by an MCZ qualified technician).

The product can be switched on again only after having eliminated the cause permanently.

12-CLEANING

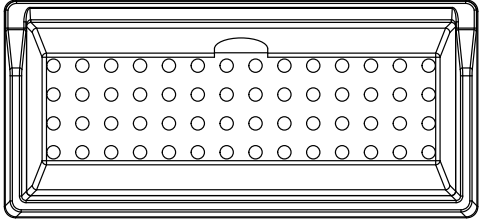

EXAMPLE OF A CLEAN BRAZIER

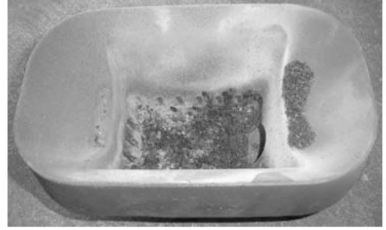

EXAMPLE OF A DIRTY BRAZIER



ATTENTION!

All the cleaning operations of all parts must be performed with the product completely cold and the plug disconnected.

The product requires little maintenance if used with certified good quality pellets.

DAILY OR WEEKLY CLEANING PERFORMED BY THE USER

Before each lighting

Clean the ash and any deposits in the brazier that could clog the air passage holes.

If the pellets in the hopper run out, unburned pellets may accumulate in the brazier. Always empty the residue in the brazier before each ignition.



REMEMBER THAT ONLY A CORRECTLY POSITIONED AND CLEAN BRAZIER CAN GUARANTEE IGNITION AND OPTIMAL OPERATION OF YOUR PELLET PRODUCT.

For the brazier to be cleaned properly, remove it from its housing completely and thoroughly clean all the holes and the grate on the bottom. If good quality pellets are used, you will normally only need to use a brush to restore the optimal operating conditions of the component.

After a long period of inactivity, **(using a vacuum cleaner with a long pipe)** remove any traces of pellets in the hopper that could have absorbed moisture and are no longer suitable for combustion.

CLEANING THE GLASS

It is recommended to clean the ceramic glass with a dry brush, or if it is very dirty, spray a little specific detergent and clean with a cloth.



ATTENTION!

Do not use abrasive products and do not spray the glass cleaning product on the painted parts and on the door gaskets (ceramic fibre cord).

12-CLEANING

CLEANING THE AIR FILTER

When the stove is installed, one must fit the rear of the stove with the wire mesh air filter, whose purpose is to prevent dirt entering the motor body and the internal sensor.

It is recommended to check that the filter is clean every 15/20 days. If needed remove fluff or the material that has deposited on it.

Inspection and cleaning are required more frequently if there are pets in the house.

To clean, simply turn the knob that holds the filter on the air intake pipe and remove the filter by turning it in the direction indicated by the arrow. To clean it use a brush or a damp cloth or compressed air.

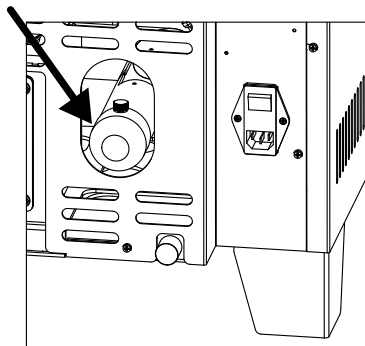

The filter is made of metallic mesh and is soft and flexible to the touch therefore, when cleaning, be careful not to crush or damage it. In the event of breakage it must be replaced.

ATTENTION!

Never let the stove work without the air filter fitted. MCZ cannot be held liable for any damage caused to the internal components if this requirement is not complied with.

12-CLEANING

CHECK EVERY 2 / 3 DAYS

Clean and empty the ash pan "C" beware of hot ashes.

The ash can be removed when it is completely cold with a vacuum cleaner. In this case, use a suitable vacuum cleaner to remove particles of a certain size. The quality of the pellets used and user experience will determine the required cleaning frequency. **However, it is recommended not to exceed 2 or 3 days.**

Once the operation is complete, put the ash pan back in place under the brazier making sure it is inserted properly.

Open the stove door, remove brazier "A" and clean around it. Then remove ash pan "C" and grate "B". Clean everything with the vacuum cleaner and reassemble the parts.

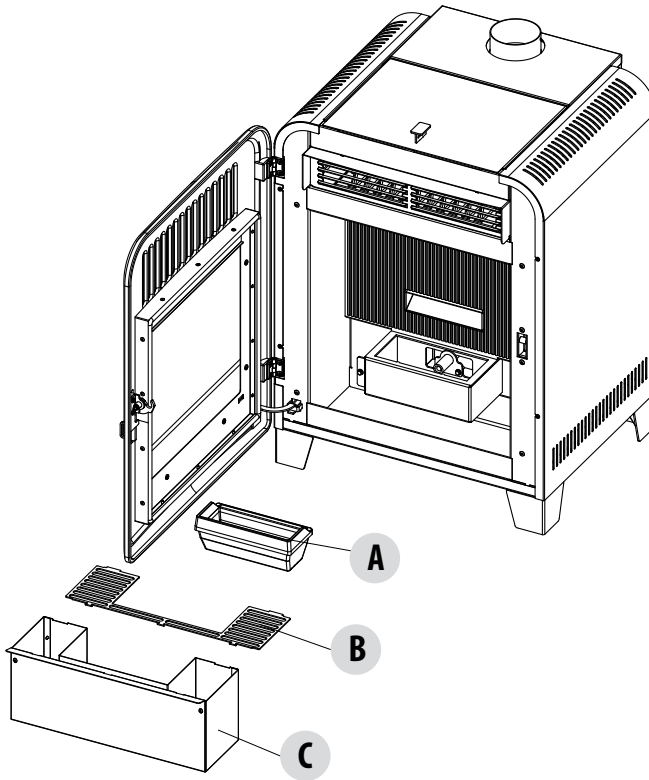

LOWER COMPARTMENT
CLEANING

12-CLEANING

PERIODIC CLEANING PERFORMED BY A QUALIFIED TECHNICIAN CLEANING THE LOWER COMPARTMENT

Half-way through the winter season, **but especially at the end**, the compartment through which the exhaust smoke passes will need to be cleaned.

This cleaning process is mandatory in order to facilitate the general removal of all combustion residue, before it becomes very difficult to remove it due to the humidity compacting it over time.

Remove the front inspection cap "E" by undoing the three screws "F". Remove any ash residues using the vacuum cleaner.

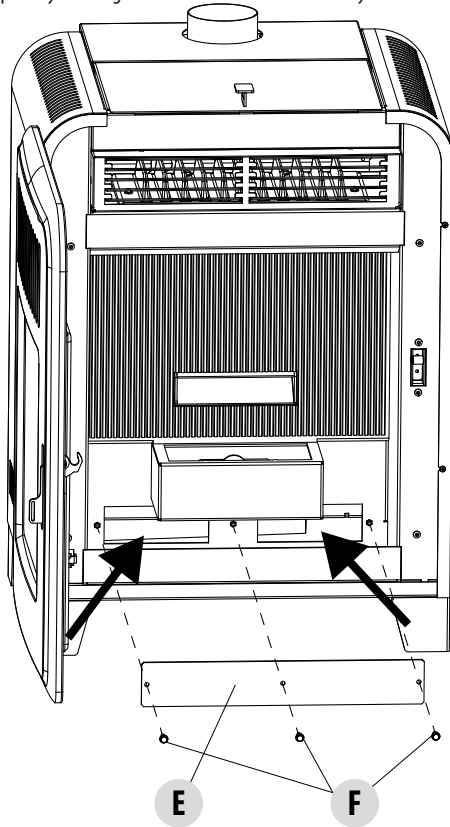

CLEANING THE SMOKE DUCT AND GENERAL CHECKS

Clean the smoke outlet, especially around the fittings, bends and any horizontal sections.

For information on cleaning the flue, contact a chimney sweep.

After having cleaned the smoke duct remove the cap "S", on the back of the stove, via the four screws "V" and vacuum any ash deposits. If needed replace the gasket "U" and put the cap "S" back in place.

Check the seal of the ceramic fibre gaskets on the door of the stove. If necessary, order new replacement gaskets from the retailer or contact an authorised service centre to carry out the operation.



ATTENTION:

The frequency with which the smoke outlet system is cleaned depends on the use of the boiler and the type of installation.

We recommend relying on an authorised service centre for end-of-season cleaning and maintenance, as they will carry out all of the previously mentioned work and inspect the stove components.

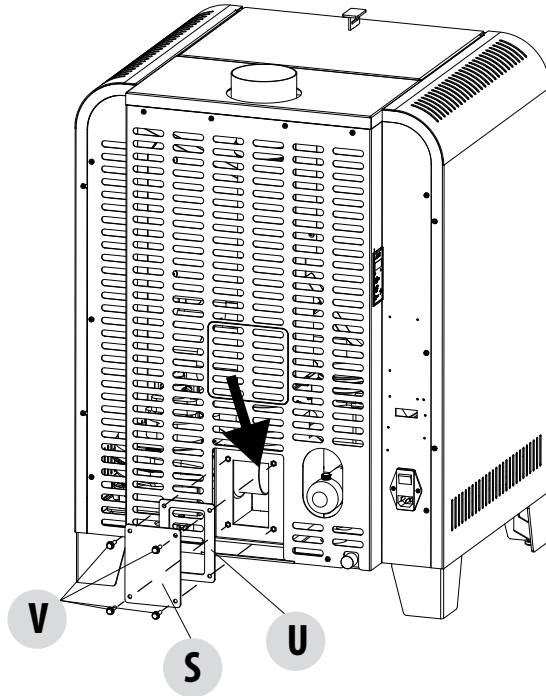

SHUTDOWN (end of season)

At the end of each season, before switching the product off, it is recommended to remove all the pellets from the hopper with a vacuum cleaner with a long pipe.

When not in use the appliance must be disconnected from the mains power supply. It is recommended to remove the power cable for additional safety, especially in the presence of children.

The service fuse may have to be replaced if the control panel display does not switch on when the product is switched on again by pressing the main switch on its side.

There is a fusebox on the side of the product, near the power socket. Open the fusebox cover with a screwdriver and replace the fuses if necessary (3.15 A delayed) - seek assistance from an authorised and qualified technician.

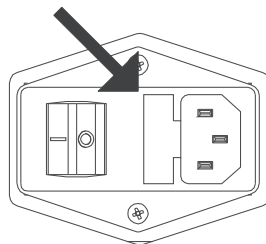

12-CLEANING

CHECKING THE INTERNAL COMPONENTS



ATTENTION!

The internal electromechanical components must only be checked by qualified personnel whose technical expertise includes combustion and electricity.

We recommend that an annual maintenance service is carried out (with a scheduled service contract). This service is essentially a visual and functional inspection of the internal components. The following is a summary of the checks and/or maintenance that are essential for the correct operation of the product.

PARTS/INTERVAL	1 DAY	2-3 DAYS	15/20 DAYS	180 DAYS	1 YEAR
Brazier	•				
Ash pan		•			
Glass		•			
Front inspection cap				•	
Rear inspection cap (with smoke duct cleaning)					•
Smoke duct					•
Gaskets					•
Air filter			•		
Remote control battery					•

13-FAULTS/CAUSES/SOLUTIONS



ATTENTION!

All repairs must only be carried out by a specialised technician, with the product switched off and the plug disconnected.

ANOMALY	POSSIBLE CAUSES	SOLUTIONS
The pellets are not fed into the combustion chamber.	The pellet hopper is empty.	Fill the hopper with pellets.
	Sawdust has blocked the feed screw.	Empty the hopper and remove the sawdust from the feed screw by hand.
	Faulty gear motor.	Replace the gear motor.
	Faulty circuit board.	Replace the circuit board.
The fire goes out or the boiler stops automatically.	The pellet hopper is empty.	Fill the hopper with pellets.
	The pellets are not fed.	See the previous anomaly.
	The pellet temperature safety probe has been triggered.	Let the boiler cool down, restore the thermostat until the problem is resolved and switch the boiler back on. If the problem persists contact Technical Assistance.
	Chrono active.	Check if the chrono setting is active.
	The door is not closed properly or the gaskets are worn.	Close the door and replace the gaskets with original ones.
	Unsuitable pellets.	Change the type of pellets with those recommended by the manufacturer.
	Low pellet supply.	Check the flow of fuel following the instructions in the manual.
	The combustion chamber is dirty.	Clean the combustion chamber, following the instructions in the manual.
	Clogged outlet.	Clean the smoke duct.
	Faulty smoke extraction motor.	Check the motor and replace it, if necessary.

13-FAULTS/CAUSES/SOLUTIONS

ANOMALY	POSSIBLE CAUSES	SOLUTIONS
The product works for a few minutes and then switches off.	Start-up phase is not completed.	Repeat start-up.
	Temporary power cut.	Wait for the automatic restart.
	Clogged smoke duct.	Clean the smoke duct.
	Faulty or malfunctioning temperature probes.	Check and replace the probes.
Pellets accumulate in the brazier, the glass of the door gets dirty and the flame is weak.	Insufficient combustion air.	Make sure that the air inlet in the room is fitted and clear. Clean the brazier and check that all the holes are clear. Perform a general cleaning of the combustion chamber and the smoke duct. Check the condition of the door gaskets.
	Damp or unsuitable pellets.	Change the type of pellets.
	Faulty smoke evacuation motor.	Check the motor and replace it, if necessary.
The smoke evacuation motor does not work.	No electrical supply to the boiler.	Check the mains voltage and the protection fuse.
	The motor is faulty.	Check the motor and capacitor and replace them, if necessary.
	Defective circuit board.	Replace the circuit board.
	The control panel is broken.	Replace the control panel.
The convection air fan never stops.	Thermal probe defective or faulty.	Check the probe and replace it, if necessary.
	Fan faulty.	Wait a few minutes and check motor operation, replace it if necessary.
	The product has not reached the shutdown temperature yet.	Wait.

13-FAULTS/CAUSES/SOLUTIONS

ANOMALY	POSSIBLE CAUSES	SOLUTIONS
The air fan does not switch on.	The product has not reached the temperature.	Wait.
The remote control does not work.	The remote control battery is flat.	Replace the battery.
	Remote control faulty.	Replace the remote control.
The product always runs at maximum power when in automatic mode.	The room thermostat is in the maximum position.	Reset the temperature of the remote control.
	Malfunctioning temperature probe.	Check the probe and replace it if necessary.
	Faulty or malfunctioning control panel.	Check the panel and replace if necessary.
The product does not switch on.	No power supply.	Check that the plug is inserted and the main switch is in the "I" position.
	Fuse tripped due to a fault.	Replace the fuse with one with same characteristics (5x20 mm F 3.15A).
	Check the brazier.	Clean the brazier and remove any deposits or residues of non-burned pellets.
	Check the position of the brazier.	Put the brazier back in its place.
	Check that the ignition plug warms up.	Check and if necessary, replace.
	Clogged smoke outlet or smoke duct.	Clean the smoke outlet and/or the smoke duct.
	Faulty ignition plug.	Replace the ignition plug.

14-CIRCUIT BOARD

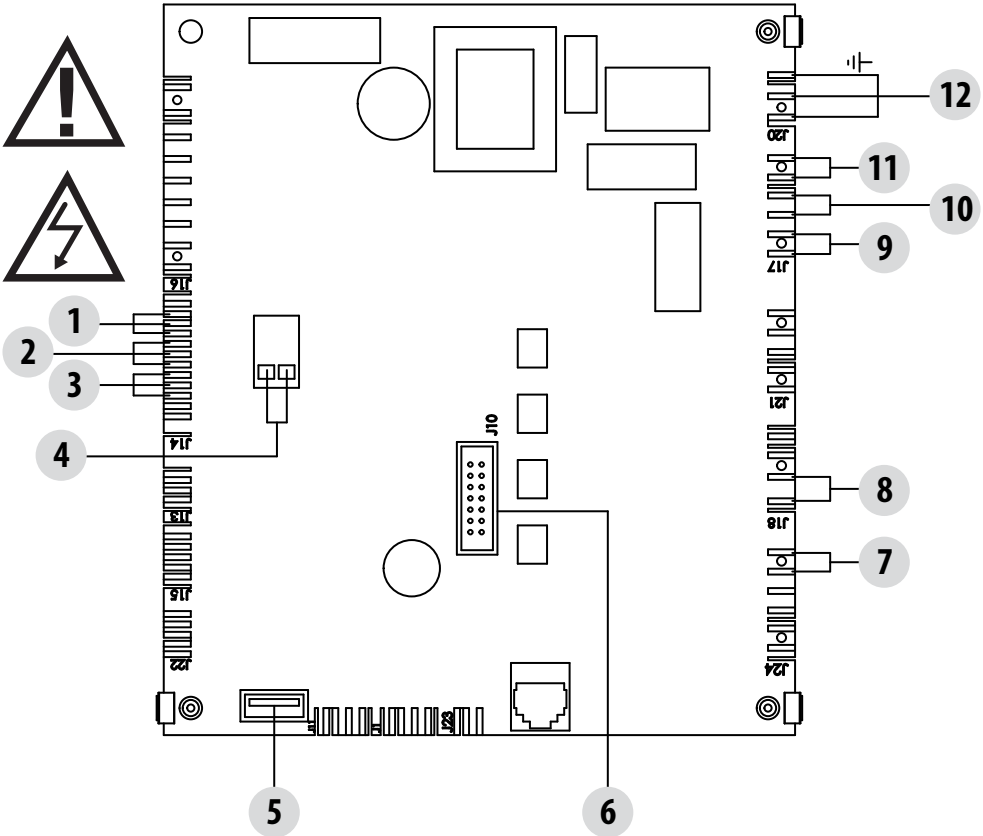

MOTHERBOARD WIRING KEY

1. SMOKE FAN ENCODER	8. AIR FAN
2. GEAR MOTOR ENCODER	9. GEAR MOTOR
3. PRESSURE TRANSDUCER	10. SMOKE FAN
4. SMOKE TEMPERATURE PROBE	11. SPARK PLUG
5. SOFTWARE UPDATE	12. SWITCH
6. EMERGENCY PANEL	
7. HOPPER OVERLOAD CUT-OUT	

PLEASE NOTE The electrical wiring of individual components is fitted with pre-wired connectors of different sizes.



Via La Croce n°8
33074 Vigonovo di Fontanafredda (PN) – ITALY
Telephone: +39 0434/599599 r.a.
Fax: +39 0434/599598
Internet: www.mcz.it
e-mail: info.red@mcz.it